

**Features**

- ◆ Broad Bandwidth
- ◆ Specified from 50MHz to 20GHz
- ◆ Usable from 50MHz to 26.5GHz
- ◆ Lower Insertion Loss and Higher Isolation than Comparable pHemtp Designs
- ◆ Rugged Fully Monolithic, Glass Encapsulated Construction
- ◆ Up to +30dBm C.W. Power Handling @ + 25°C

**Description**

The MA4SW110, MA4SW210 and MA4SW310 are broadband monolithic switches using series and shunt connected silicon PIN diodes. They are designed for use as moderate signal, high performance switches in applications up to 26.5GHz. They provide performance levels superior to those realized by hybrid MIC designs incorporating beam lead and PIN chip diodes that require chip and wire assembly.

These switches are fabricated using M/A-COM's patented HMIC™ (Heterolithic Microwave Integrated Circuit) process, US Patent 5,268,310. This process allows the incorporation of silicon pedestals that form series and shunt diodes or vias by imbedding them in low loss, low dispersion glass. By using small spacing between elements, this combination of silicon and glass gives HMIC devices low loss and high isolation performance through low millimeter frequencies.

Large bond pads facilitate the use of low inductance ribbon leads, while gold backside metallization allows for manual or automatic chip bonding via 80/20 , AuSn solder or conductive Ag epoxy.

**Absolute Maximum Ratings @ T<sub>A</sub>+25°C**

Parameter	Absolute Maximum
Operating Temperature	-65°C to +125°C
Storage Temperature	-65°C to +150°C
Junction Temperature	+175°C
Applied Reverse Voltage	- 50V
RF C.W. Incident Power	+30dBm C.W.
Bias Current +25°C	±20mA

**Max. operating conditions for a combination of RF power, D.C. bias and temperature:**  
+30dBm CW @ 15mA (per diode) @+85°C

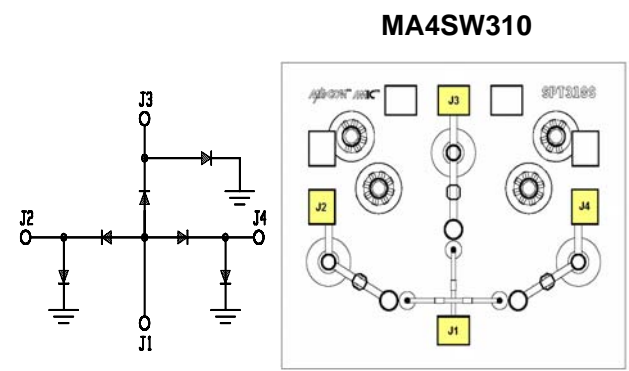
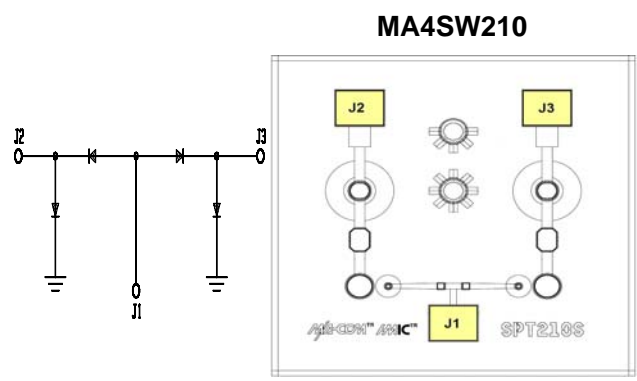
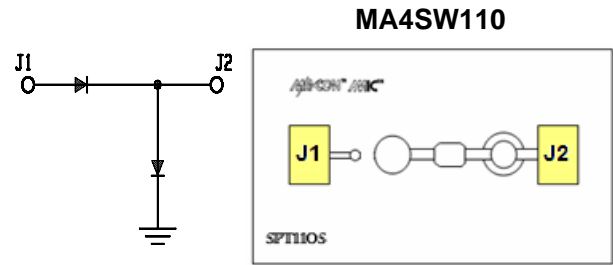

**ADVANCED:** Data Sheets contain information regarding a product M/A-COM is considering for development. Performance is based on target specifications, simulated results, and/or prototype measurements. Commitment to develop is not guaranteed.  
**PRELIMINARY:** Data Sheets contain information regarding a product M/A-COM has under development. Performance is based on engineering tests. Specifications are typical. Mechanical outline has been fixed. Engineering samples and/or test data may be available. Commitment to produce in volume is not guaranteed.

• **North America** Tel: 800.366.2266 / Fax: 978.366.2266  
 • **Europe** Tel: 44.1908.574.200 / Fax: 44.1908.574.300  
 • **Asia/Pacific** Tel: 81.44.844.8296 / Fax: 81.44.844.8298  
 Visit [www.macom.com](http://www.macom.com) for additional data sheets and product information.  
 M/A-COM Inc. and its affiliates reserve the right to make changes to the product(s) or information contained herein without notice.

**HMIC™ Silicon PIN Diode Switches**  
**RoHS Compliant**

M/A-COM Products  
Rev. V6

**MA4SW110 (SPST)**

Electrical Specifications @ T<sub>A</sub> = +25°C, 20mA

Parameter	Frequency	Minimum	Nominal	Maximum	Units
Insertion Loss	6GHz	-	0.4	0.7	dB
	13GHz	-	0.5	0.9	dB
	20GHz	-	0.7	1.2	dB
Isolation	6GHz	46	55	-	dB
	13GHz	39	47	-	dB
	20GHz	34	42	-	dB
Input Return Loss	6GHz	22	31	-	dB
	13GHz	15	33	-	dB
	20GHz	14	27	-	dB
Switching Speed <sup>1</sup>	-	-	20	-	ns
Voltage Rating <sup>2</sup>	-	-	-	50	V
Signal Compression (500mW)	1GHz	-	0.2	-	dB

- 1.) Typical Switching Speed measured from 10 % to 90 % of detected RF signal driven by TTL compatible drivers.
- 2.) Maximum reverse leakage current in either the shunt or series PIN diodes shall be 10mA maximum at -50 volts.

**MA4SW210 (SPDT)**

Electrical Specifications @ T<sub>A</sub> = +25°C, 20mA

Parameter	Frequency	Minimum	Nominal	Maximum	Units
Insertion Loss	6GHz	-	0.4	0.7	dB
	13GHz	-	0.5	1.0	dB
	20GHz	-	0.7	1.2	dB
Isolation	6GHz	48	63	-	dB
	13GHz	40	50	-	dB
	20GHz	34	42	-	dB
Input Return Loss	6GHz	20	27	-	dB
	13GHz	18	25	-	dB
	20GHz	15	25	-	dB
Switching Speed <sup>1</sup>	-	-	20	-	ns
Voltage Rating <sup>2</sup>	-	-	-	50	V
Signal Compression (500mW)	1GHz	-	0.2	-	dB

- 1.) Typical Switching Speed measured from 10 % to 90 % of detected RF signal driven by TTL compatible drivers.
- 2.) Maximum reverse leakage current in either the shunt or series PIN diodes shall be 10mA maximum at -50 volts.

**MA4SW310 (SP3T)**

Electrical Specifications @ T<sub>A</sub> = +25°C, 20mA

Parameter	Frequency	Minimum	Nominal	Maximum	Units
Insertion Loss	6GHz	-	0.5	0.8	dB
	13GHz	-	0.7	1.1	dB
	20GHz	-	0.9	1.5	dB
Isolation	6GHz	49	57	-	dB
	13GHz	42	48	-	dB
	20GHz	33	42	-	dB
Input Return Loss	6GHz	20	24	-	dB
	13GHz	14	22	-	dB
	20GHz	11	21	-	dB
Switching Speed <sup>1</sup>	-	-	20	-	ns
Voltage Rating <sup>2</sup>	-	-	-	50	V
Signal Compression (500mW)	1GHz	-	0.2	-	dB

**ADVANCED:** Data Sheets contain information regarding a product M/A-COM is considering for development. Performance is based on target specifications, simulated results, and/or prototype measurements. Commitment to develop is not guaranteed.

**PRELIMINARY:** Data Sheets contain information regarding a product M/A-COM has under development. Performance is based on engineering tests. Specifications are typical. Mechanical outline has been fixed. Engineering samples and/or test data may be available. Commitment to produce in volume is not guaranteed.

- **North America** Tel: 800.366.2266 / Fax: 978.366.2266
- **Europe** Tel: 44.1908.574.200 / Fax: 44.1908.574.300
- **Asia/Pacific** Tel: 81.44.844.8296 / Fax: 81.44.844.8298

Visit [www.macom.com](http://www.macom.com) for additional data sheets and product information.

M/A-COM Inc. and its affiliates reserve the right to make changes to the product(s) or information contained herein without notice.

Typical Performance Curves at  $T_A = +25^\circ\text{C}$ , 20mA Bias Current

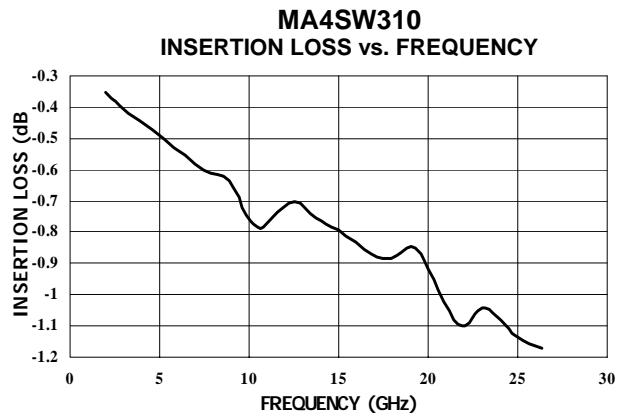
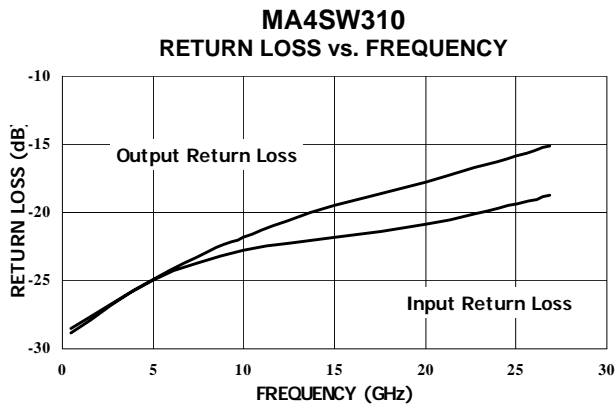
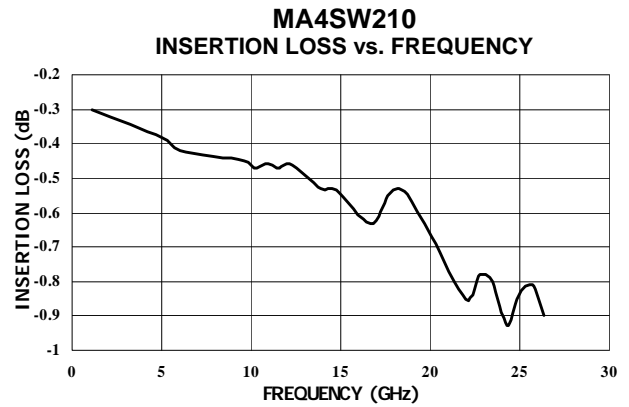
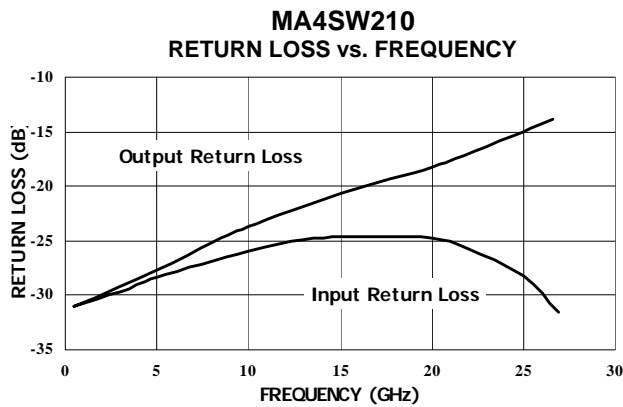
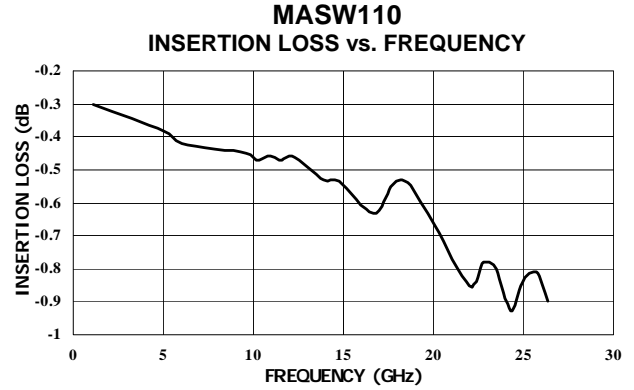
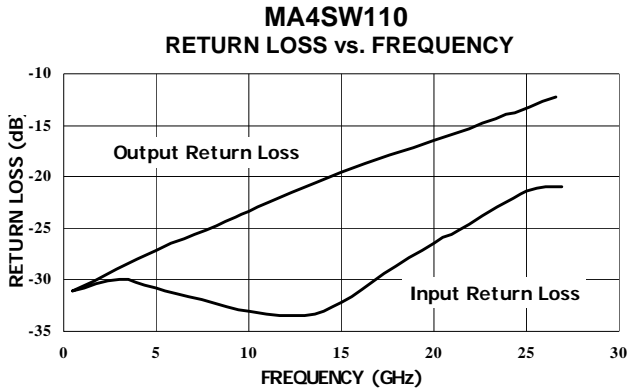

**S-Parameters:** S-Parameter data for these devices are available upon request.

**ADVANCED:** Data Sheets contain information regarding a product M/A-COM is considering for development. Performance is based on target specifications, simulated results, and/or prototype measurements. Commitment to develop is not guaranteed.

**PRELIMINARY:** Data Sheets contain information regarding a product M/A-COM has under development. Performance is based on engineering tests. Specifications are typical. Mechanical outline has been fixed. Engineering samples and/or test data may be available. Commitment to produce in volume is not guaranteed.

- **North America** Tel: 800.366.2266 / Fax: 978.366.2266
- **Europe** Tel: 44.1908.574.200 / Fax: 44.1908.574.300
- **Asia/Pacific** Tel: 81.44.844.8296 / Fax: 81.44.844.8298

Visit [www.macom.com](http://www.macom.com) for additional data sheets and product information.

M/A-COM Inc. and its affiliates reserve the right to make changes to the product(s) or information contained herein without notice.

Typical Performance Curves @ TA = +25°C, 20mA Bias Current

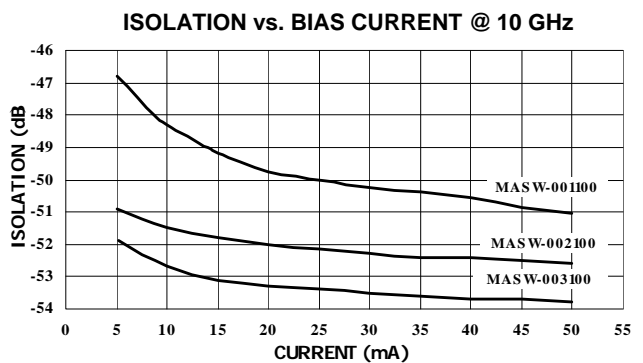
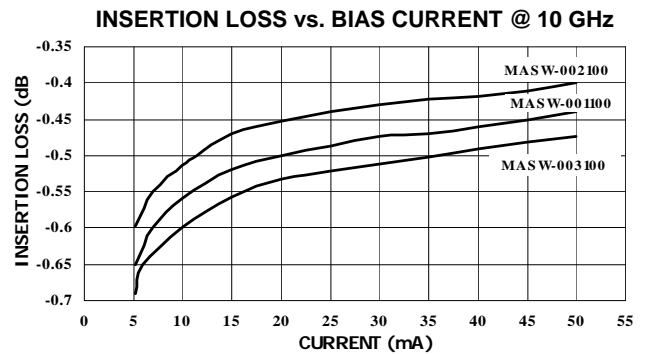
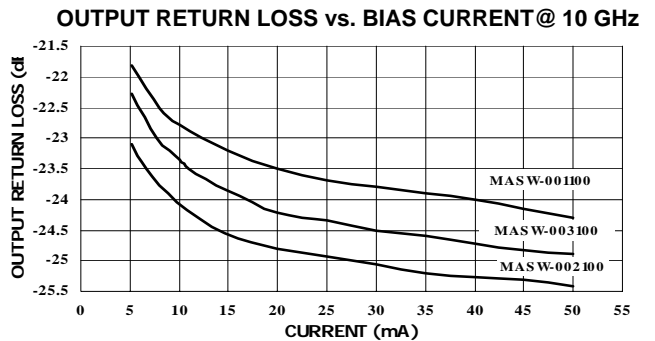
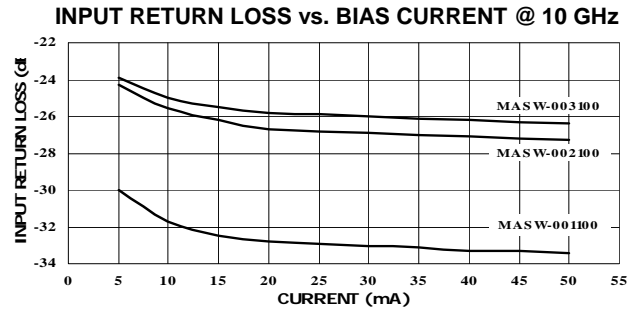
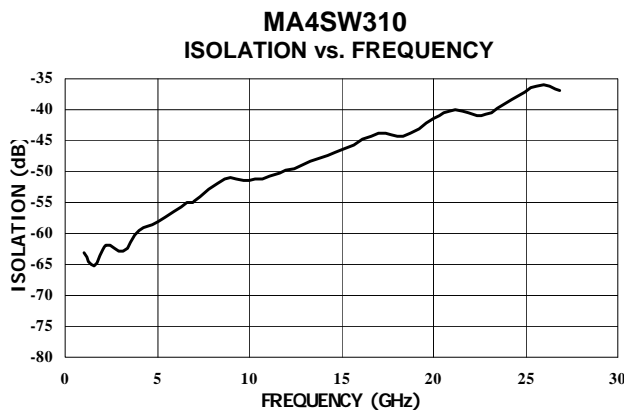
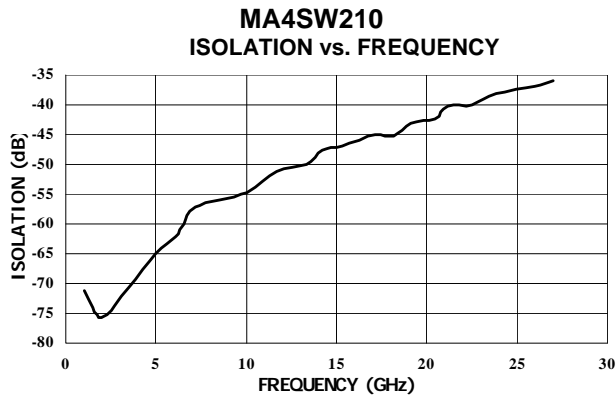
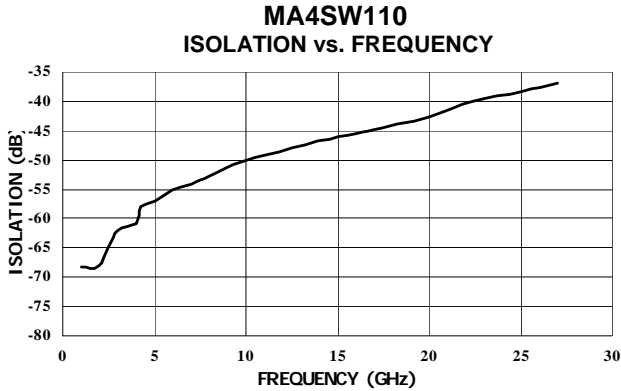

**ADVANCED:** Data Sheets contain information regarding a product M/A-COM is considering for development. Performance is based on target specifications, simulated results, and/or prototype measurements. Commitment to develop is not guaranteed.

**PRELIMINARY:** Data Sheets contain information regarding a product M/A-COM has under development. Performance is based on engineering tests. Specifications are typical. Mechanical outline has been fixed. Engineering samples and/or test data may be available. Commitment to produce in volume is not guaranteed.

- **North America** Tel: 800.366.2266 / Fax: 978.366.2266
- **Europe** Tel: 44.1908.574.200 / Fax: 44.1908.574.300
- **Asia/Pacific** Tel: 81.44.844.8296 / Fax: 81.44.844.8298

Visit [www.macom.com](http://www.macom.com) for additional data sheets and product information.

M/A-COM Inc. and its affiliates reserve the right to make changes to the product(s) or information contained herein without notice.

### Operation of the MA4SW Series Switches

Operation of the MA4SW series of PIN switches is achieved by simultaneous application of a negative DC current to the low loss switching arm J1, J2, or J3, and a positive DC current to the remaining switching arms as shown in the bias connection circuits. DC return is achieved via J1. The control currents should be supplied by constant current sources. The voltages at these points will not exceed  $\pm 1.5$  volts (1.2 volts typical) at currents up to  $\pm 20$ mA. In the low loss state, the series diode must be forward biased and the shunt diode reverse biased. In the isolated arm, the shunt diode is forward biased and the series diode is reverse biased.

### Driver Connections MA4SW110

Control Level DC Current @	Condition of RF Output
J2	J1-J2
-20mA	Low Loss
+20mA	Isolation

### MA4SW210

Control Level DC Current @		Condition of RF Output	Condition of RF Output
J2	J3	J1-J2	J1-J3
-20mA	+20mA	Low Loss	Isolation
+20mA	-20mA	Isolation	Low Loss

### MA4SW310

Control Level DC Current @			Cond. of RF Output	Cond. of RF Output	Cond. of RF Output
J2	J3	J4	J1-J2	J1-J3	J1-J4
-20mA	+20mA	+20mA	Low Loss	Isolation	Isolation
+20mA	-20mA	+20mA	Isolation	Low Loss	Isolation
+20mA	+20mA	-20mA	Isolation	Isolation	Low Loss

### Handling Considerations

**Cleanliness:** These chips should be handled in a clean environment.

**Electro-Static Sensitivity:** The MA4SW Series PIN diode switches are ESD, Class 1A sensitive (HBM). The proper ESD handling procedures should be used.

**ADVANCED:** Data Sheets contain information regarding a product M/A-COM is considering for development. Performance is based on target specifications, simulated results, and/or prototype measurements. Commitment to develop is not guaranteed.

**PRELIMINARY:** Data Sheets contain information regarding a product M/A-COM has under development. Performance is based on engineering tests. Specifications are typical. Mechanical outline has been fixed. Engineering samples and/or test data may be available. Commitment to produce in volume is not guaranteed.

### MA4SW110 and Bias Connections<sup>1</sup>

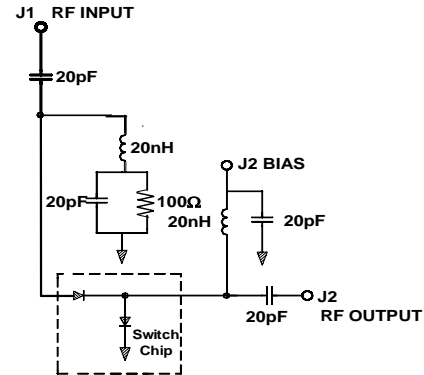

### MA4SW210 and Bias Connections<sup>1</sup>

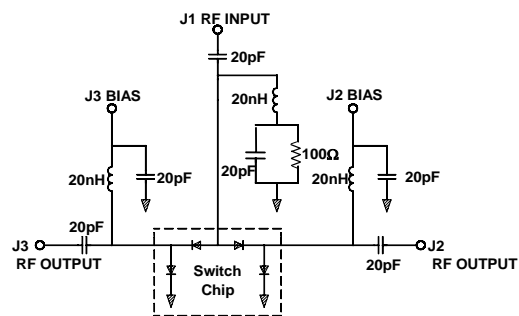

### MA4SW310 and Bias Connections<sup>1</sup>

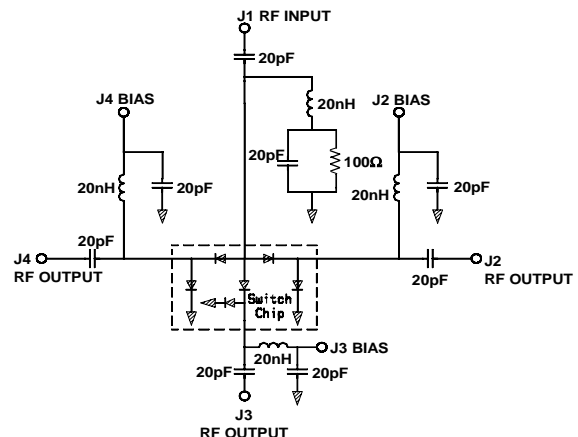

**Notes:**

1. RLC values are for an operation frequency of 2-18GHz and bias current of  $\pm 20$ mA per diode.

- **North America** Tel: 800.366.2266 / Fax: 978.366.2266
  - **Europe** Tel: 44.1908.574.200 / Fax: 44.1908.574.300
  - **Asia/Pacific** Tel: 81.44.844.8296 / Fax: 81.44.844.8298
- Visit [www.macom.com](http://www.macom.com) for additional data sheets and product information.

M/A-COM Inc. and its affiliates reserve the right to make changes to the product(s) or information contained herein without notice.

### Wire Bonding

Thermosonic wedge wire bonding using 0.003" x 0.00025" ribbon or 0.001" diameter gold wire is recommended. A stage temperature of 150°C and a force of 18 to 22 grams should be used. Ultrasonic energy should be adjusted to the minimum required to achieve a good bond. RF bond wires should be kept as short as possible.

### Mounting

The HMIC switches have Ti-Pt-Au back metal. They can be die mounted with a gold-tin eutectic solder preform or conductive epoxy. Mounting surface must be clean and flat.

**Eutectic Die Attachment:** An 80/20, gold-tin, eutectic solder preform is recommended with a work surface temperature of 255°C and a tool tip temperature of 265°C. When hot gas is applied, the tool tip temperature should be 290°C. The chip should not be exposed to temperatures greater than 320°C for more than 20 seconds. No more than three seconds should be required for attachment. Solders containing tin should not be used.

**Epoxy Die Attachment:** Surface of assembly should be preheated to 125-150°C. A minimum amount of epoxy should be used. A thin epoxy fillet should be visible around the perimeter of the chip after placement. Cure epoxy per manufacturer's schedule.

## MA4SW110 Chip Outline Drawing<sup>1,2</sup>

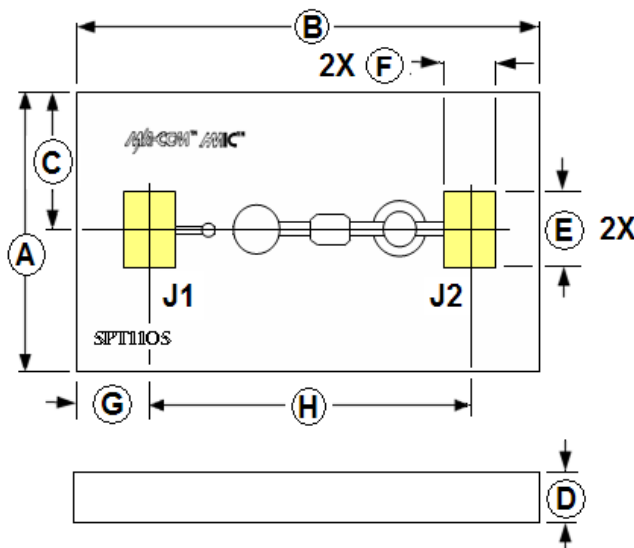

DIM	INCHES		MM	
	MIN.	MAX.	MIN.	MAX.
A	0.014	0.018	0.35	0.45
B	0.025	0.029	0.64	0.74
C	0.008 REF		0.20 REF	
D	0.004	0.006	0.10	0.15
E	0.004 REF		0.10 REF	
F	0.003 REF		0.08 REF	
G	0.003 REF		0.08 REF	
H	0.020 REF		0.52 REF	

### Notes:

1. Topside and backside metallization is gold, 2.5mm thick typical.
2. Yellow areas indicate wire bonding pads

**ADVANCED:** Data Sheets contain information regarding a product M/A-COM is considering for development. Performance is based on target specifications, simulated results, and/or prototype measurements. Commitment to develop is not guaranteed.

**PRELIMINARY:** Data Sheets contain information regarding a product M/A-COM has under development. Performance is based on engineering tests. Specifications are typical. Mechanical outline has been fixed. Engineering samples and/or test data may be available. Commitment to produce in volume is not guaranteed.

- **North America** Tel: 800.366.2266 / Fax: 978.366.2266
- **Europe** Tel: 44.1908.574.200 / Fax: 44.1908.574.300
- **Asia/Pacific** Tel: 81.44.844.8296 / Fax: 81.44.844.8298

Visit [www.macom.com](http://www.macom.com) for additional data sheets and product information.

M/A-COM Inc. and its affiliates reserve the right to make changes to the product(s) or information contained herein without notice.

### MA4SW210 Chip Outline Drawing<sup>1,2</sup>

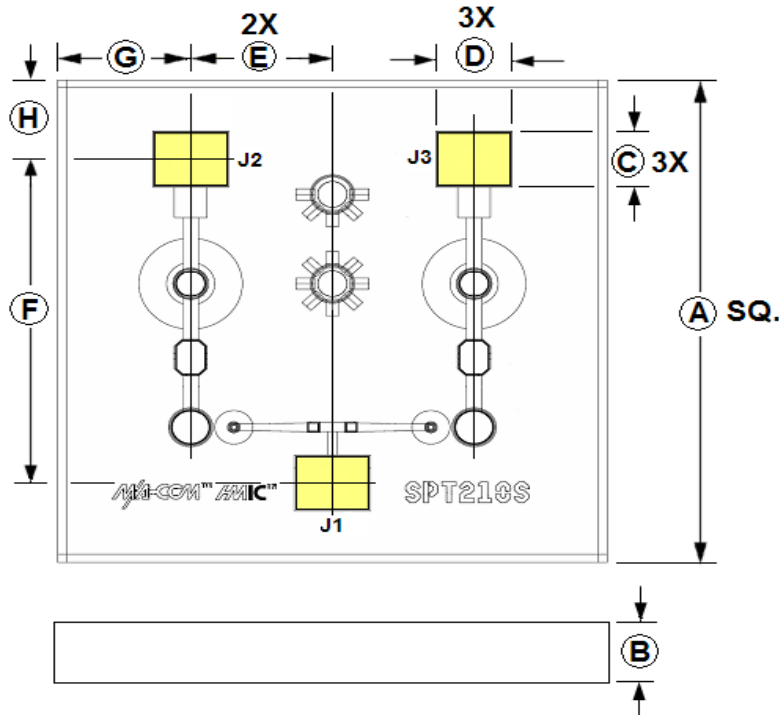

DIM	INCHES		MM	
	MIN.	MAX.	MIN.	MAX.
A	0.029	0.033	0.73	0.83
B	0.004	0.006	0.10	0.15
C	0.004 REF		0.10 REF	
D	0.005 REF		0.13 REF	
E	0.009 REF		0.23 REF	
F	0.023 REF		0.58 REF	
G	0.007 REF		0.17 REF	
H	0.004 REF		0.10 REF	

**Notes:**

1. Topside and backside metallization is gold , 2.5mm thick typical.
2. Yellow areas indicate wire bonding pads

**ADVANCED:** Data Sheets contain information regarding a product M/A-COM is considering for development. Performance is based on target specifications, simulated results, and/or prototype measurements. Commitment to develop is not guaranteed.

**PRELIMINARY:** Data Sheets contain information regarding a product M/A-COM has under development. Performance is based on engineering tests. Specifications are typical. Mechanical outline has been fixed. Engineering samples and/or test data may be available. Commitment to produce in volume is not guaranteed.

- **North America** Tel: 800.366.2266 / Fax: 978.366.2266
- **Europe** Tel: 44.1908.574.200 / Fax: 44.1908.574.300
- **Asia/Pacific** Tel: 81.44.844.8296 / Fax: 81.44.844.8298

Visit [www.macom.com](http://www.macom.com) for additional data sheets and product information.

M/A-COM Inc. and its affiliates reserve the right to make changes to the product(s) or information contained herein without notice.



### MA4SW310 Chip Outline Drawing <sup>1, 2</sup>

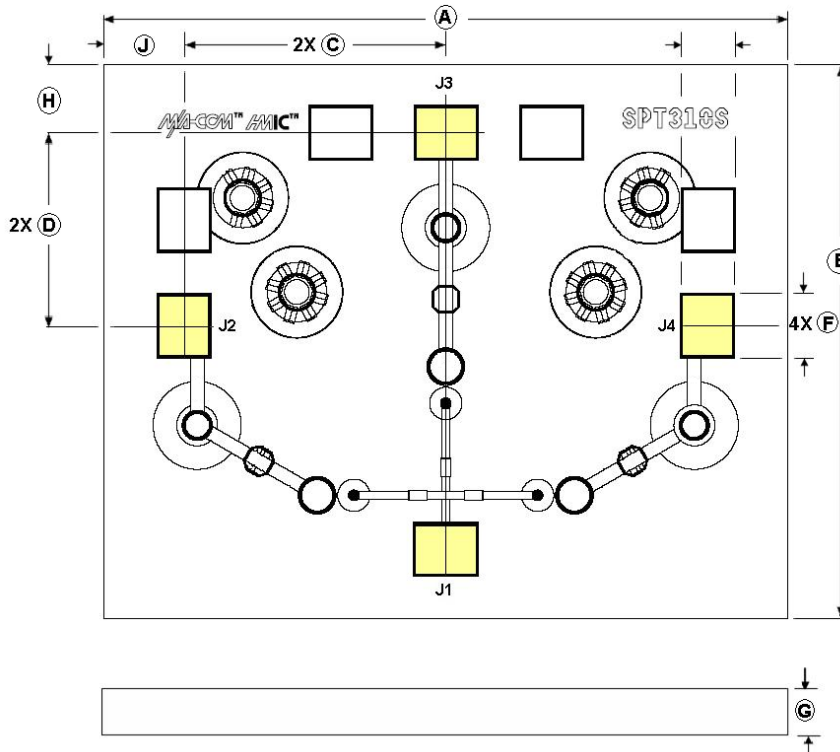

DIM	INCHES		MM	
	MIN.	MAX.	MIN.	MAX.
A	0.046	0.050	1.16	1.26
B	0.036	0.040	0.92	1.02
C	0.019 REF		0.48 REF	
D	0.014 REF		0.36 REF	
E	0.004 REF		0.10 REF	
F	0.005 REF		0.13 REF	
G	0.004	0.006	0.10	0.15
H	0.005 REF		0.12 REF	
J	0.004 REF		0.10 REF	

**Notes:**

1. Topside and backside metallization is gold , 2.5mm thick typical.
2. Yellow areas indicate wire bonding pads

**ADVANCED:** Data Sheets contain information regarding a product M/A-COM is considering for development. Performance is based on target specifications, simulated results, and/or prototype measurements. Commitment to develop is not guaranteed.

**PRELIMINARY:** Data Sheets contain information regarding a product M/A-COM has under development. Performance is based on engineering tests. Specifications are typical. Mechanical outline has been fixed. Engineering samples and/or test data may be available. Commitment to produce in volume is not guaranteed.

- **North America** Tel: 800.366.2266 / Fax: 978.366.2266
- **Europe** Tel: 44.1908.574.200 / Fax: 44.1908.574.300
- **Asia/Pacific** Tel: 81.44.844.8296 / Fax: 81.44.844.8298

Visit [www.macom.com](http://www.macom.com) for additional data sheets and product information.

M/A-COM Inc. and its affiliates reserve the right to make changes to the product(s) or information contained herein without notice.